

1

2

3

4

A

A

B

B

C

C

D

D

E

E

F

F

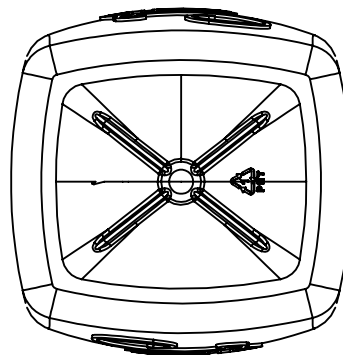
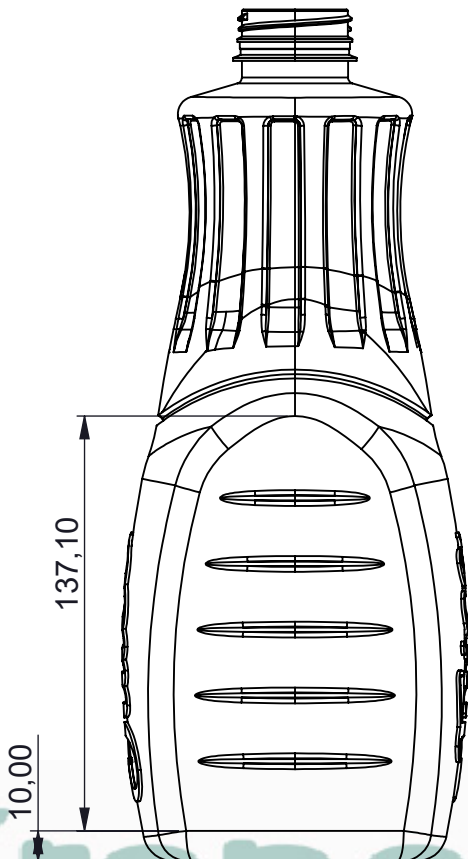

Overflow 2065  $\pm 1\%$   
(Densidade 1.00g/cm<sup>3</sup>)

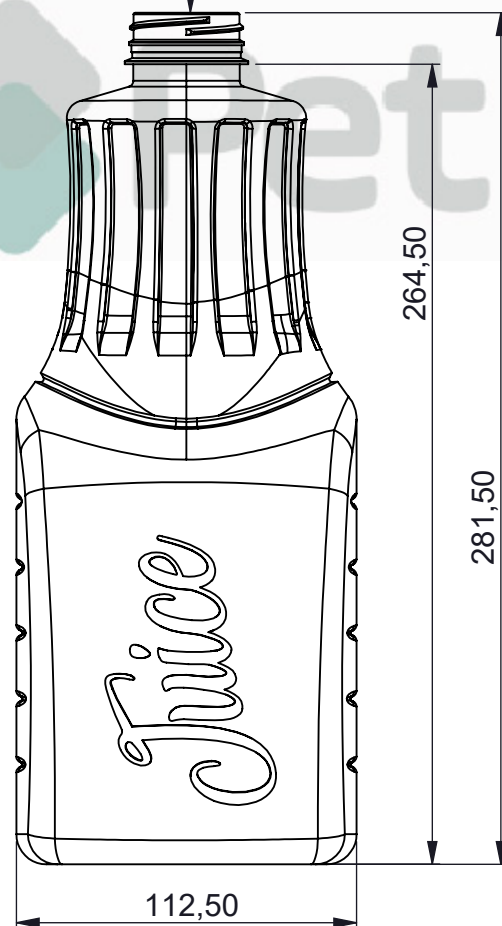
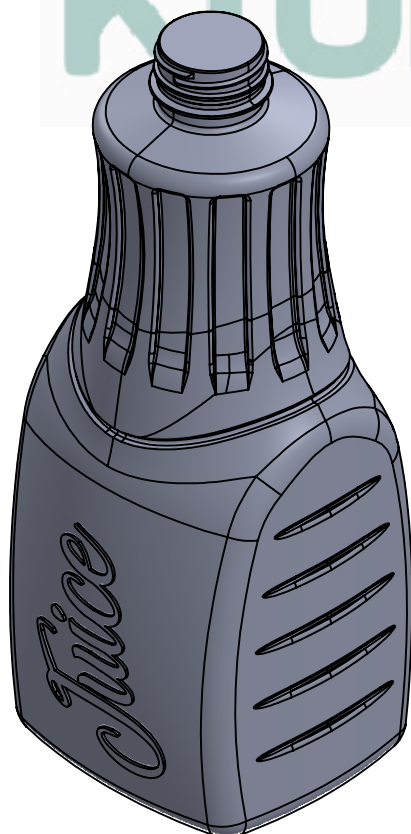

-	-	FE19	PET	38mm	-	50G
<b>ITEM</b>	<b>QTD.</b>	<b>DESCRIÇÃO</b>	<b>MATERIAL</b>	<b>DIM. BOCAL</b>	<b>DIM. BRUTA</b>	<b>MASSA [g]</b>
<b>ARQUIVO CAD:</b> C:\Users\doug\Downloads\DESENHOS EMBAPLAST\3D\IFE19- Frasco Pet Suco 2000ml						
<b>TRAT. TÉRM.:</b>	-	<b>DES.</b>	<b>DATA</b>	<b>TÍTULO:</b>		
<b>CLIENTE:</b>	-	DOUGLAS	18/04/2022	Frasco Pet suco 2000ml		
<b>ESC.</b>	1:2	<b>PROJ.</b>	<b>DATA</b>			
		DOUGLAS	18/04/2022	<b>DESENHO N°</b>		<b>FORM. REV.</b>
		<b>APROV.</b>	<b>DATA</b>	FE19		A4 -

1

2

3

IMPRESSÃO EM 18/04/2022