

DETALHE C  
ESCALA 2 : 1

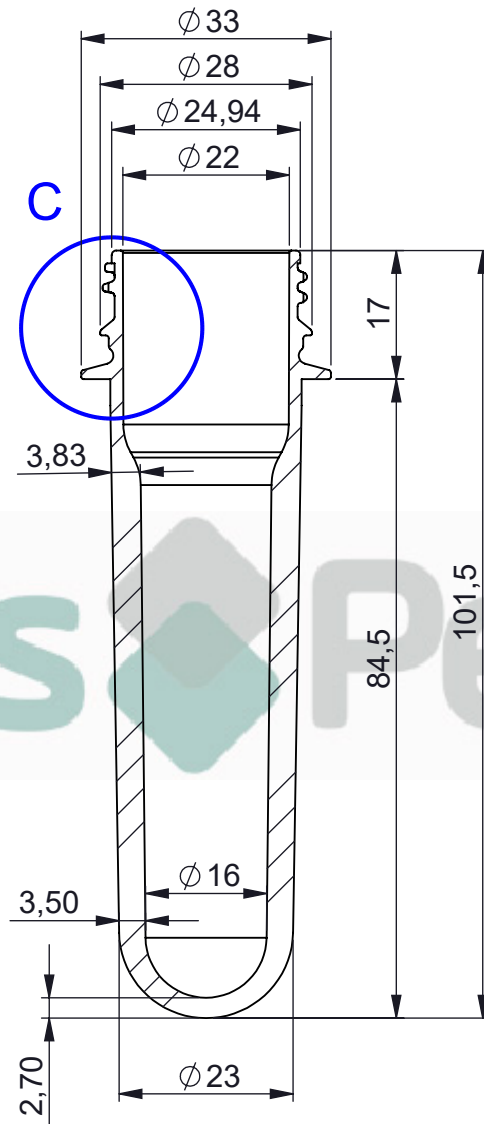
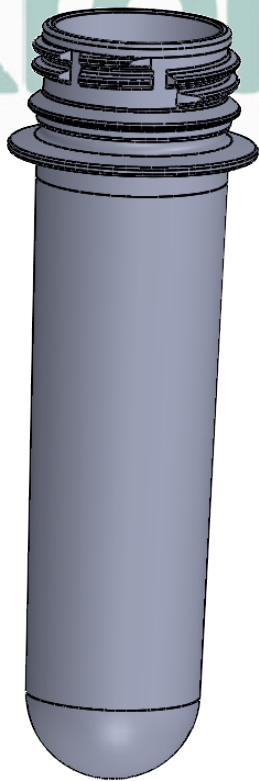

Kronos Pet

-	-	PREFORMA 28 1881 27g	PET	28 1881	-	27g
ITEM	QTD.	DESCRIÇÃO	MATERIAL	DIM. BOCAL	DIM. BRUTA	MASSA [g]
ARQUIVO CAD: D:\TRABALHO\DESENVOLVIMENTO\MOLDE 27g\PREFORMA 28 1881 27g						
TRAT. TÉRM.: -		DES. CLEITON	DATA 02/02/2023	TÍTULO: PK65 PREFORMA 28 1881 27g		
CLIENTE: -		PROJ. CLEITON	DATA 02/02/2023	DESENHO N° -		
ESC. 1:2		APROV.	DATA			

Kronos Pet